

# PHILIPS

## Bridge Box

Connected by  
WiZ Pro



## Datasheet

### WiZ Pro TW Bridge Box I 12-24V

929002499509

#### Enabling connected lighting system for welcoming spaces

Philips WiZ Pro TW bridge box can work with constant voltage LED transformer to enable tunable white control features. It enables simple, cost effective wireless lighting system for energy saving and comfort. Advanced design of the bridge box helps to build a reliable and standardized connected lighting system with different functionalities from simple wireless dimming to cloud based operations.

#### Benefits

- Easy wireless dimming and scheduling for energy saving and convenience
- Connecting to Wi-Fi for cloud-based control and remote access. No gateway needed
- Future-proof flexibility, support OTA (Over-The-Air) firmware update
- Large array of integrations to work with popular home assistant systems
- WiZ Click feature enables easy installation
- CE certified

#### Features

- PWM dimming method with 2 channel outputs
- Suitable for both independent and built-in usage
- Energy metering feature with 10% accuracy
- Max 180W output load
- 50,000 hours lifetime
- Wi-Fi + Bluetooth dual protocol module which enable local Bluetooth messages for installation and connectivity to WiZ cloud over Wi-Fi network
- Include WiZ Pro software suite prepaid license  
WiZ Pro software to install: [pro.wizconnected.com](http://pro.wizconnected.com)  
WiZ Pro software to install for China: [pro.wizconnected.cn](http://pro.wizconnected.cn)

#### Application

- Residential
- Hospitality
- Restaurant
- Retail
- School
- Leisure places

## Logistical data

Specification item	value
Product name	WiZ Pro TW Bridge Box I 12-24V
12NC	929002499509
Pieces per box	40 pcs

## Product Data

All specifications are typical and at 25 °C Tcase unless otherwise specified.

### Electrical data

Specification item	Value	Unit	Conditions
Rated input voltage	12..24	Vdc	
Rated input current	7.5	A	
Max input power	180	W	
Rated output current	7.5A max total 7.5A max per channel;	A	
Standby power	0.50	W	
ESD	4KV @ HBM, 8KV @ air		

Notes:

- 1) Compatible with Constant Voltage SELV driver only.

### Dimming Interface

Specification item	Value	Unit	Conditions
Dimming method	PWM, 2KHz;		
Dimming range	5-100	%	

### RF interface

Specification item	Value	Unit	Conditions
Communication method	Wi-Fi + BLE		
Wi-Fi Frequency	2400-2483.5	MHz	IEEE Std 802.11 b/g.
Wi-Fi Transmission power	20	dbm	Maximum
BLE Frequency	2400-2483.5	MHz	
BLE Transmission power	3	dbm	Maximum
Wi-Fi channel	1..13		

### Indicator

Specification item	Value
LED indicator	Blue Color, indicating the pairing status and other procedures
Push button	Tact switch, for pairing and factory reset

Notes:

- 1) Press for under <2s and release : product does a soft reboot, LED status blink 1 time
- 2) Press for 2s ~ 10s and release : product goes into forced pairing mode, outputs dimming variations, LED status pulsing
- 3) Press for >10s and release : reset to factory settings (forgets favorites and Home ID) and reboots, LED status blinks 10 times after reset is done

### Operational temperature and humidity

Specification item	Value	Unit	Conditions
Ambient temperature	-20..+50	°C	
Relative humidity	10..90	%	
Tcase_life	70	°C	
Tcase_max	70	°C	

### Storage temperature and humidity

Specification item	Value	Unit	Conditions
Ambient temperature	-25...+85	°C	
Relative humidity	5...95	%	

### Lifetime

Specification item	Value	Unit	Conditions
Lifetime	50,000	Hours	@ Tcase_life. Maximum failures=10%
Switch cycles	100,000	Cycles	

### Certificates and standards

Specification item	Value
Approval marks	CE, WFA, BQB, Independent installation
Environment	RoHS, REACH
Connection	Wi-Fi IEEE802.11 b/g, BLE 4.2
Audible noise	< 24 dB @5cm
Ingress Protection	IP20

Notes:

Hereby, [Signify] declares that the radio equipment type [WiZ bridge boxes] is in compliance with Directive 2014/53/EU (RED). The full text of the EU declaration of conformity is available at the following internet address: [wizconnected.com](http://wizconnected.com).

### Energy Metering

Specification item	Value	Unit	Conditions
Energy Metering accuracy	< 10	%	@ Full power

Notes:

- 1) Energy metering is for reference use only. It is not intended to be used as a measurement instrument for any commercial purpose.
- 2) Energy metering is NOT referable when input current is less than 0.5A.

## Wiring & Connections

Specification item	Value	Unit	Conditions
Input Wire Type	1.5	mm <sup>2</sup>	Strand wire; Red for +, Black for -; Tolerance: +/- 0.1mm <sup>2</sup>
Output Wire Type for negative (CW/WW)	1.5	mm <sup>2</sup>	Strand wire, Black; Tolerance: +/- 0.1mm <sup>2</sup>
Output Wire Type for Positive	1.5	mm <sup>2</sup>	Strand wire, Red; Tolerance: +/- 0.1mm <sup>2</sup>
Wire Length	130	mm	Tolerance: +/- 5mm
Wire Strip Length	10	mm	Tolerance: +/- 5mm

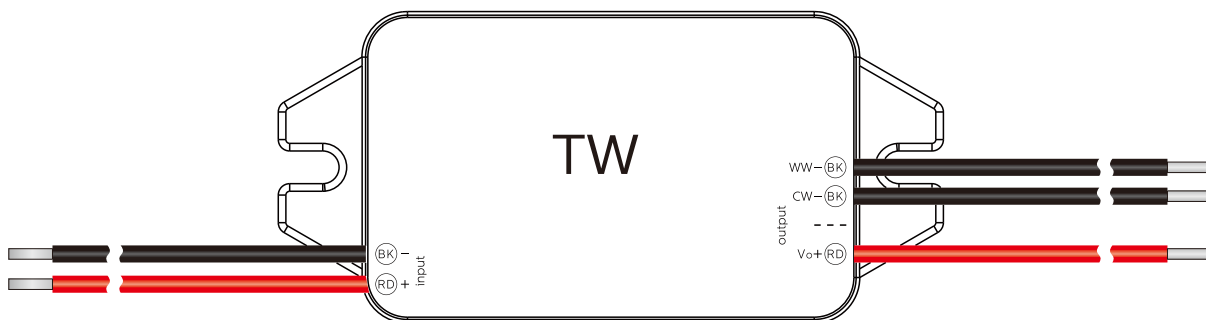

## Example of connection:

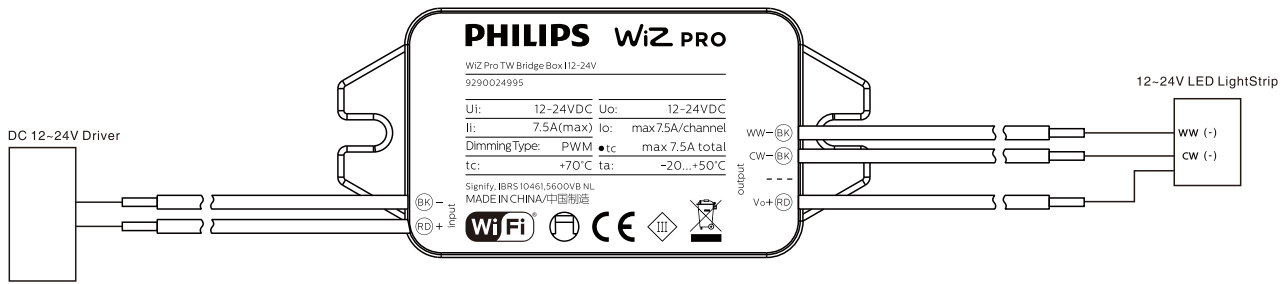

1. Disconnect the power supply lines.
2. Use accessory screws to fix the product through the u-shaped groove on both sides.
3. Following instructions of silk print on the housing of bridge, then plug the output wires into LED light strip input connectors.
4. Plug the input positive and negative wire of the bridge into **SELV constant voltage driver** output connectors.

## Wire definition:

	Specification item	Definition	Remark
A	WW (-) - Black	Output: Warm White LED strip	
B	CW (-) - Black	Output: Cool White LED strip	
C	Vo (+) - Red	Output: LED strip V+	
D	V (-) - Black	DC power supply negative input	
E	V (+) - Red	DC power supply positive input	
F	Push button	Reset button	
G	LED light	LED light	

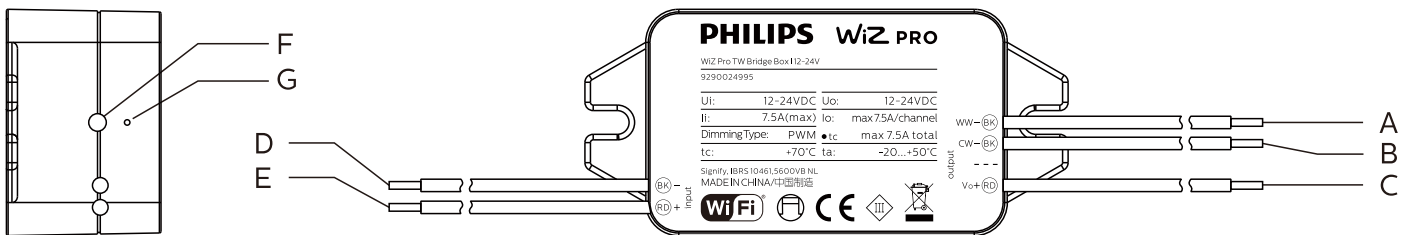

## Dimensions and weight

Specification item	Value	Unit	Conditions
Dimensions L x W x H	88 x 41.2 x 28	mm	Tolerance: +/- 0.1mm
Color	White		
Weight	55	gram	

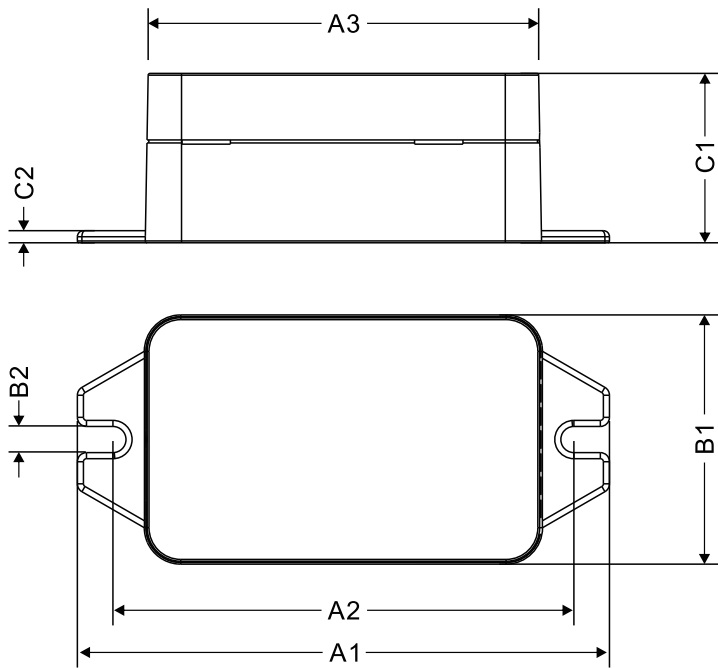

Data sheet	
Item	Dimensions
A1	88mm ±0.1
A2	76.2mm ±0.1
A3	64.6mm ±0.1
A4	130mm ±5
A5	10mm ±5
A6	130mm ±5
B1	41.2mm ±0.1
B2	4.3mm ±0.1
C1	28mm ±0.1
C2	2mm ±0.1
a	1.5mm <sup>2</sup> ±0.1
D	2.26mm ±0.1
Gross Weight: 0.055 KG	

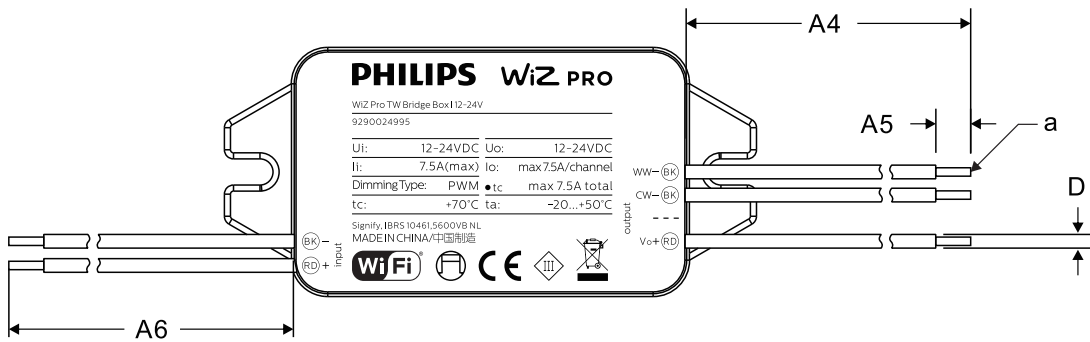

## Download free Wiz APP



- Wi-Fi®, the Wi-Fi logo, the Wi-Fi CERTIFIED logo are registered trademarks of Wi-Fi Alliance.
- Wi-Fi CERTIFIED™, WPA2™ are trademarks of Wi-Fi Alliance.
- The Bluetooth® word mark and logos are registered trademarks owned by Bluetooth SIG, Inc.
- Amazon, Alexa and all related logos are trademarks of Amazon.com, Inc. or its affiliates. Google, Google Play and the Google Play logo are the trademark of Google LLC. The Apple logo and Siri are the registered trademark of Apple Inc.
- Any use of such marks by Signify is under license. Other trademarks and trade names are those of their respective owners.



© 2021 Signify Holding, IBRS 10461, 5600VB, NL. All rights reserved.

<https://www.wizconnected.com/en/pro/get-started/>

The information provided herein is subject to change, without notice. Signify does not give any representation or warranty as to the accuracy or completeness of the information included herein and shall not be liable for any action in reliance thereon. The information presented in this document is not intended as any commercial offer and does not form part of any quotation or contract, unless otherwise agreed by Signify.

Philips and the Philips Shield Emblem are registered trademarks of Koninklijke Philips N.V. All other trademarks are owned by Signify Holding or their respective owners.

08/2021

Data subject to change