

# SensorDIM™ - Integrated HF Sensor and LED Driver

# HYTRONIK®

## HEC7028

Tri-level Control with Daylight Monitoring and Remote Control

### Applications

Occupancy sensor and constant current LED driver, 2-in-1.







Suitable for building into the fixture for:

- Office / Commercial Lighting
- Classroom
- Meeting Room

Use for retrofit and new luminaire designs/installations



### Features

-  24 hour daylight monitoring dawn/dusk sensor
-  One-touch daylight learning via remote control
-  Tri-level dimming control based upon occupancy (also known as corridor function)
-  16 programs are built-in for quick installation by a 'click' on the rotary switch
-  Easy-on-the-eye operation which makes the light turning on/off less uncomfortable
-  DIP switch offers multiple current selections for different luminaire requirements
-  5 Year, 50,000hr Warranty

### Technical Data

#### Input Characteristics

Model No.	HEC7028
Mains voltage	220~240VAC 50/60Hz
Input current	0.15 - 0.14A
Input power	32.5W
Warming-up	20s

#### Safety and EMC

EMC standard (EMC)	EN55015, EN61547, EN6100-2/3
Safety standard (LVD)	EN61347-1, EN61347-2-13
Dielectric strength	Input→output: 3750VAC / 5mA / 1min
Abnormal protection	Output short-circuit protection
Certification	Semko, CB, CE, EMC, RED, SAA

CE  RED  SAA CB IP20

#### Sensor Data

Model No.	HEC7028
Sensor principle	High Frequency (microwave)
Operation frequency	5.8GHz +/- 75MHz
Transmission power	<0.2mW
Detection range	Max. (Ø x H) 8m x 5m
Detection angle	30° ~ 150°

#### Driver Data

Empty load voltage	60V
Power factor	≥0.9
Efficiency	85% (Max.)
Output current	350/500/550/700/750/900mA

#### Environment

Operation temperature	Ta: -20°C ~ +50°C
Case temperature (Max.)	Tc: +75°C
IP rating	IP20

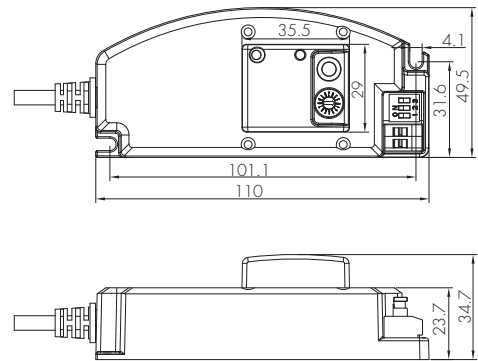
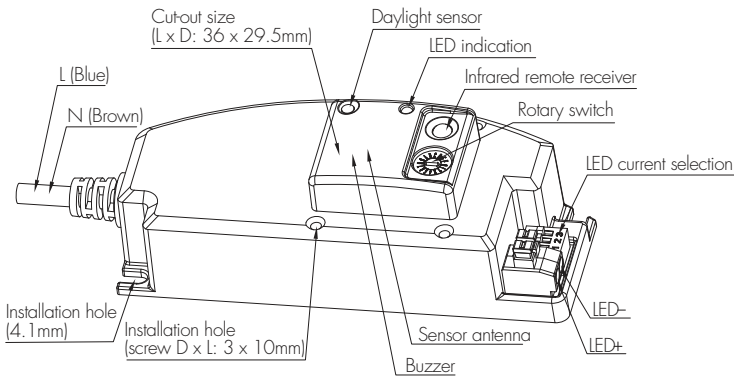

2 in 1 and cost effective! This is a smart integration of microwave motion sensor and multiple current selection LED driver, which gives pre-selected constant current to drive the LEDs to work based upon movement detection.

## Sensor Functions and Features

### 1 24h Daylight Monitoring Function

Our innovative and patented software enables our antenna with built-in daylight sensor to provide a "smart photocell" function. This function is activated when stand-by period is set to "+∞".



The light switches on at 100% when there is movement detected.

The light dims to stand-by level after the hold-time.

The light remains in dimming level at night.

#### Settings on this demonstration:

Hold-time: 10min  
Daylight threshold: 50lux  
Stand-by dimming level: 10%  
Stand-by period: +∞

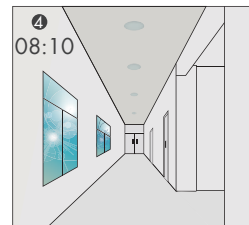
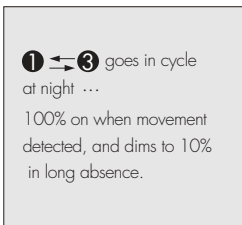

The light turns off completely when natural light lux exceeds daylight threshold pre-set.



The light automatically turns on at 10% when natural light is insufficient (no motion).

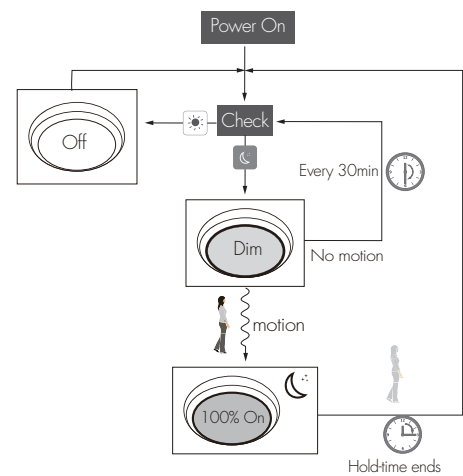

## 2 Tri-level Control (Corridor Function)

Hytronik builds this function inside the motion sensor to achieve tri-level control, for some areas which require a light change notice before switch-off. The sensor offers 3 levels of light: 100%-->dimmed light (natural light is insufficient) -->off; and 2 periods of selectable waiting time: motion hold-time and stand-by period; Selectable daylight threshold and freedom of detection area.



With sufficient natural light, the light does not switch on when presence is detected.

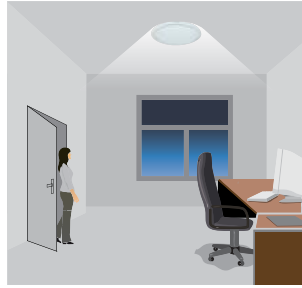

With insufficient natural light, the sensor switches on the light automatically when presence is detected.

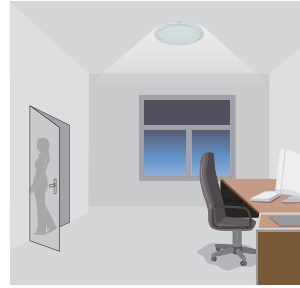

After hold-time, the light dims to stand-by level if the surrounding natural light is below the daylight threshold.



Light switches off automatically after the stand-by period elapses.

## 3 Rotary Switch Programming

Instead of the DIP switches, end user can easily choose the settings by the rotary switch. There are total 16 channels / combinations which could meet different requirements in real application:

Channel	Detection range	Hold-time	Daylight sensor	Stand-by period	Stand-by dim. level
0	100%	5s	Disable	10s	10%
1	100%	30s	2Lux	1min	10%
2	100%	1min	2Lux	5min	10%
3	100%	1min	10Lux	10min	10%
4	100%	1min	Disable	+∞	10%
5	100%	5min	2Lux	10min	10%
6	100%	5min	10Lux	30min	10%
7	100%	5min	Disable	+∞	10%
8	100%	10min	2Lux	10min	10%
9	100%	10min	10Lux	30min	10%
A	100%	10min	Disable	+∞	10%
B	50%	10min	Disable	30min	10%
C	10%	10min	Disable	10min	10%
D	100%	30min	10Lux	30min	10%
E	100%	30min	Disable	+∞	10%
F	100%	5s	2Lux	10s	10%



Note: end-user can also scan the QR code on the housing for sensor settings.

## 4 Assembly

The sensor antenna features the rotary switch (or DIP switches) and protrudes the LED panel. This feature enables the end user to access the sensor settings without removing the gear tray / LED board.



The QR code links the installer to the user manual on the on-line user guide to check the detail of settings (program).



Cutout size: 36 x 29.5 (mm)

## Settings (Remote Control HRC-05)



### Permanent ON/OFF function

Press the "ON/OFF" button, the light goes to permanent on or permanent off mode, and the sensor is disabled.

\* Press "Auto Mode", "RESET" or "Scene mode" buttons to quit this mode.



### Sensor mode

Press "Auto Mode" button, the sensor starts to function and all settings remain the same as the latest status before the light is switched on/off.



### Reset function

Press "RESET" button, all settings go back to default settings.



### Dim +/-

Long press "Dim +" or "Dim -" to adjust the light brightness during hold-time. "+" means dimming up, "-" means dimming down.



### Test mode

This button is for testing purpose only. The sensor goes to test mode (hold-time is 2s) after commissioning, meanwhile the stand-by period and daylight sensor are disabled.

\* This mode can be ended by pressing "reset", or any button of "scene mode" and "hold-time". The sensor settings are changed accordingly.



### Power output

By pressing these two buttons, the output shifts between 80% (at initial 10,000 hours) and 100%, for energy saving purpose.



### Ambient daylight threshold

Press this button, the latest surrounding lux value overwrites the previous lux value learned, and it is set as the daylight threshold. This feature enables the fixture to function well in any real application circumstances.



### Lux disable

Press this button, the built-in daylight sensor stops working, and all motion detected could turn on the lighting fixture, no matter how bright the natural light is.

### Scene mode

There are 4 scene modes fixed program built in the remote control to choose for different applications:

Scene options	Detection range	Hold-time	Stand-by period	Stand-by dimming level	Daylight sensor
SC1	100%	1 min	10min	10%	2Lux
SC2	100%	5min	10min	10%	2Lux
SC3	100%	10min	30min	10%	10Lux
SC4	100%	10min	+∞	10%	50Lux

\* End-user can adjust the settings by pressing buttons of detection range/hold-time/stand-by period/stand-by dimming level/daylight sensor. The last setting stays in validity.

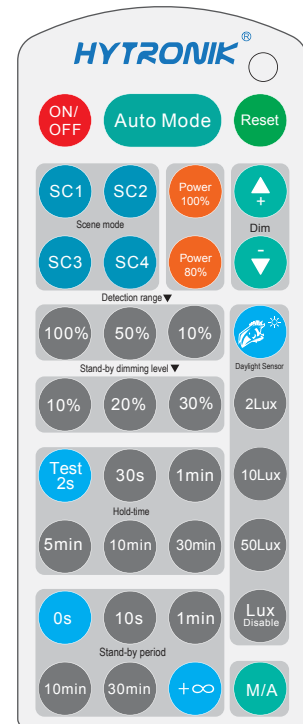

HRC-05

*Note: the buzzer beeps one time when RC receives signal successfully.*

### Detection range

Press the buttons of "detection range" to set detection range at 10% / 50% / 100%.

### Hold-time

Press the buttons of "hold-time" to set hold-time at 30s / 1min / 5min / 10min / 30min.

### Daylight sensor

Press the buttons of "daylight sensor" to set daylight threshold at 2Lux / 10Lux / 50Lux.

### Stand-by period (corridor function)

Press the buttons of "stand-by period" to set stand-by period at 0s / 10s / 1min / 10min / 30min / +∞.

\* "0s" means on/off control; "+∞" means bi-level dimming control, light never switches off when daylight sensor is disabled.

### Stand-by dimming level

Press the buttons of "stand-by dimming level" to set the stand-by dimming level at 10% / 20% / 30%.

### M/A Manual override / Semi-auto mode (absence detection)

Button "M/A" is disabled.

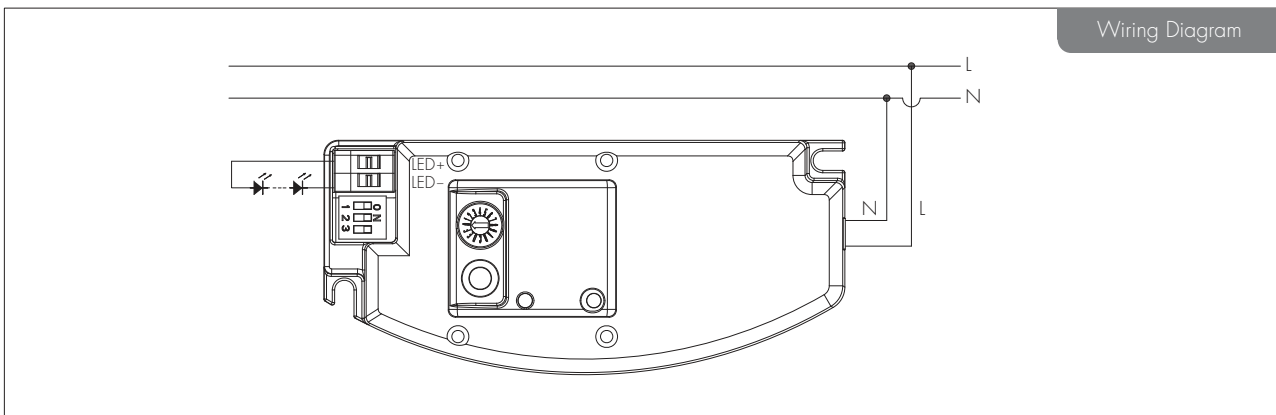

### Detection Pattern

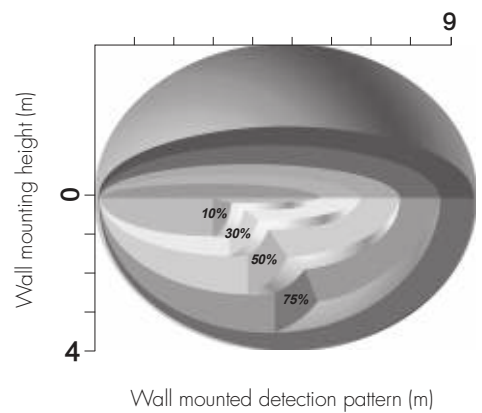
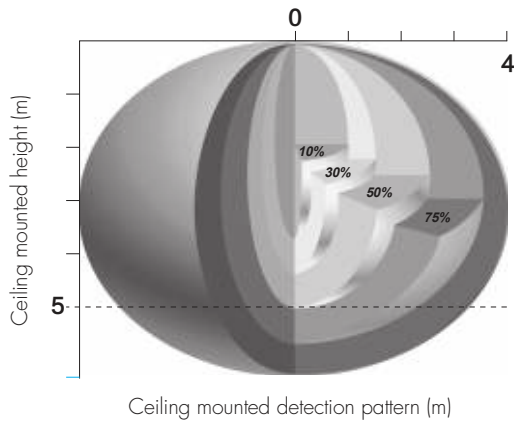

## 1 LED Current Selections



The current can be easily configured by choosing the correct combination of the DIP switches (see table on the left).

## 2 LED Maximum Load and Voltage

This multiple current LED driver has a wide range of loading capacity:

Maximum load @ different currents:	3.5~17W (350mA)	5~24W (500mA)	5.5~25W (550mA)
	7~28W (700mA)	7~28W (750mA)	9~28W (900mA)

Maximum voltage @ different currents:	10~48V (350mA)	10~48V (500mA)	10~46V (550mA)
	10~40V (700mA)	10~37V (750mA)	10~31V (900mA)